



ASSEMBLY INSTRUCTIONS

TECHART Trims

Part-no. 091.100.110.009	Aero wing trims Carrera 2 / 2S until MY16
Part-no. 091.100.111.009	Aero wing trims Carrera 4 / 4S until MY16
Part-no. 091.100.183.009	Aero wing trims Turbo until MY16
Part-no. 091.100.186.009	Aero wing trims Turbo from MY17
Part-no. 091.100.182.009	Air outlet grille
Part-no. 091.100.200.009	Headlight trims
Part-no. 091.100.320.009	Side mirror trims
Part-no. 091.100.50_009	Diffusor add-on Carrera
Part-no. 091.100.512.009	Diffusor add-on for rear apron centered outlet Carrera from MY17
Part-no. 091.100.552.009	Shaft Panel with Louvers for Rear Apron Carrera from MY17
Part-no. 091.100.58_009	Diffusor add-on Turbo
Part-no. 091.100.600.009	Roof spoiler

Version 14 – 06/2018





ASSEMBLY INSTRUCTIONS

TECHART Trims

Contents

I	Important safety information	3
II	Preparation	5
III	Installation	10
1	Prepare vehicle	10
1.1	Paint preparation	10
2	TECHART aero wing trims Carrera 2 / 2S	11
2.1	Dismantle original trim bars	11
2.2	Install TECHART aero wing trims.....	12
3	TECHART aero wing trims Carrera 4 / 4S, only for vehicles with parking sensor	14
3.1	Dismantle original trim bars	14
3.2	Prepare original grille.....	14
3.3	Install TECHART aero wing trims.....	15
4	TECHART aero wing trims Carrera 4 / 4S, only for vehicles without parking sensor	18
4.1	Dismantle original trim bars	18
4.2	Prepare original grille.....	18
4.3	Install TECHART aero wing trims.....	20
5	TECHART aero wing trims Turbo	22
5.3	Install TECHART aero wing trims.....	22
6	TECHART air outlet grille.....	23
6.1	Dismount wheels and add-on parts	23
6.2	Install TECHART air outlet grille	23
7	TECHART headlight trims.....	28
7.1	Dismantle headlight washer panels.....	28
7.2	Install TECHART headlight trims.....	28
8	TECHART side mirror trims	29
7.1	Install TECHART side mirror trims	29
9	TECHART diffusor add-on	30
9.1	Install TECHART diffusor add-on	30
10	TECHART diffusor add-on for rear apron with centered outlet for Carrera from MY17	31
10.1	Install TECHART diffusor add-on Carrera	31
11	TECHART louvers for rear apron.....	32
11.1	Install TECHART shaft panel with louvers for rear apron.....	32
12	TECHART roof spoiler	33
12.,1	Install TECHART roof spoiler	33
12	Final inspection	34









ASSEMBLY INSTRUCTIONS

TECHART Trims

I Important safety information











All of the necessary work must be performed by qualified persons with an appropriate level of expertise.

	<p style="text-align: center;">⚠ WARNING</p> <p>Vehicle lifts with an insufficient lifting capacity can collapse under the weight of the vehicle and crush any persons standing underneath.</p> <p>Compare the weight of the vehicle with the lifting capacity of your vehicle lift. The weight of the vehicle must not exceed the lifting capacity of your vehicle lift. The weight of the vehicle can be found in the vehicle operating manual.</p>	
	<p style="text-align: center;">⚠ WARNING</p> <p>Risk of injury from electric current.</p> <p>Switch off the ignition and disconnect the battery when working on the vehicle electrical/electronics systems.</p>	
   	<p style="text-align: center;">⚠ WARNING</p> <p>Risk of fire and explosion from ignition of windshield cleaning agents/antifreeze and their vapors.</p> <p>Risk of poisoning from ingesting windshield cleaning agents/antifreeze and breathing in their vapors.</p> <p>Risk of injury due to irritation caused by windshield cleaning agents/antifreeze coming into contact with eyes, skin and other parts of the body.</p> <p>Wear protective clothing and safety glasses. Avoid naked flames, fire and sources of ignition. Avoid contact with eyes, skin and other parts of the body. Do not eat, drink or smoke when handling windshield cleaning agents/antifreeze. Do not breathe in vapors and ensure adequate ventilation. Keep windshield cleaning agents/antifreeze only store them in sealable original containers.</p>	     



ASSEMBLY INSTRUCTIONS

TECHART Trims

 	<p style="text-align: center;"> CAUTION</p> <p>Risk of injury from hands and arms being crushed, cut or lacerated when working with sharp-edged and bulky objects.</p> <p>Wear protective clothing and protective gloves. Keep limbs out of narrow and inaccessible areas of the vehicle and/or avoid dangerous situations by using special tools and suitable aids.</p>	 
	<p style="text-align: center;"> CAUTION</p> <p>Risk of injury to back, muscles, joints, tendons and ligaments from lifting and carrying heavy and/or bulky objects.</p> <p>Lift and transport heavy and/or bulky objects with the help of other people and/or with suitable aids.</p>	
	<p style="text-align: center;">NOTICE</p> <p>Before starting the assembly procedure, carefully read the assembly instructions in full and pay attention to the safety information and sequence of the individual operation steps.</p>	
	<p style="text-align: center;">NOTICE</p> <p>All body parts must be prepared and painted in accordance with the attached painting guide.</p>	



ASSEMBLY INSTRUCTIONS

TECHART Trims

II Preparation

Number of people required



For the installation of this product at least two persons are needed.

Help and support

If you have any technical queries, please contact us immediately:
support@techart.de

Quantity	Part number	Part designation
1	091.100.110.009	Aero wings trims until MY16
Consisting of:		
1	091.100.110.100	Panel right
1	091.100.110.101	Panel left
4	091.100.110.110	Carrier right
1	091.100.110.111	Carrier left
1	091.100.110.200	Trim bar outside right top
1	091.100.110.201	Trim bar outside left top
1	091.100.110.210	Trim bar outside right bottom
1	091.100.110.211	Trim bar outside left bottom
1	091.100.110.220	Trim bar inside right top
1	091.100.110.221	Trim bar inside left top
4	091.100.110.230	Trim bar inside right bottom
1	091.100.110.231	Trim bar inside left bottom
6	000.100.340.900	Clip
8	000.100.999.999	Collar screw for plastic PT 50x16 with cone point
1	00091089010031	Bond and Seal black, 70 ml tube



ASSEMBLY INSTRUCTIONS

TECHART Trims

Quantity	Part number	Part designation
1	091.100.111.009	Aero wings trims Carrera 4 / 4S until MY16
Consisting of:		
1	091.100.110.100	Panel right
1	091.100.110.101	Panel left
4	091.100.110.110	Carrier right
1	091.100.110.111	Carrier left
1	091.100.110.200	Trim bar outside right top
1	091.100.110.201	Trim bar outside left top
1	091.100.110.210	Trim bar outside right bottom
1	091.100.110.211	Trim bar outside left bottom
1	091.100.110.220	Trim bar inside right top
1	091.100.110.221	Trim bar inside left top
4	091.100.110.230	Trim bar inside right bottom
1	091.100.110.231	Trim bar inside left bottom
6	000.100.340.900	Clip
8	000.100.999.999	Collar screw for plastic PT 50x16 with cone point
1	091100111204	Panel parking sensor right
1	091100111205	Panel parking sensor left
1	091100111206	Bracket parking sensor right
1	091100111207	Bracket parking sensor left
1	091100111214	Bracket without parking sensor right
1	091100111215	Bracket without parking sensor left
4	0039002.9X13995	Sheet metal raised countersunk head screw 2.9 x 13
2	0039002.9X16995	Sheet metal raised countersunk head screw 2.9 x 16
1	00091089010031	Bond and Seal black, 70 ml tube

Quantity	Part number	Part designation
1	091.100.183.009	Aero wings trims Turbo until MY16
Consisting of:		
1	091.100.183.100	Panel right
1	091.100.183.101	Panel left
1	00091089010031	Bond and Seal black, 70 ml tube



ASSEMBLY INSTRUCTIONS

TECHART Trims

Quantity	Part number	Part designation
1	091.100.186.009	Aero wings trims Turbo from MY17
Consisting of:		
1	091.100.186.100	Panel right
1	091.100.186.101	Panel left
1	00091089010031	Bond and Seal black, 70 ml tube

Quantity	Part number	Part designation
1	091.100.182.009	Air outlet grille
Consisting of:		
1	091.100.182.100	Air outlet grille
1	091.100.182.101	Bottom part
1	091.140.182.009	Cutting template for air outlet grille
12	0039003016109	Fillister head screw with flange 3.0 x 16
3	0009013X12	Rivet truss head 3.0x12

Quantity	Part number	Part designation
1	091.100.200.009	Headlight trims
Consisting of:		
1	091.100.200.100	Trim right
1	091.100.200.101	Trim left
2	097.100.220.100-01	Headlight washer system panel
1	091.100.200.102	Adhesive label headlight panel R
1	091.100.200.103	Adhesive label headlight panel L
1	00091089010031	Bond and Seal black, 70 ml tube

Quantity	Part number	Part designation
1	091.100.320.009	Side mirror trims
Consisting of:		
1	091.100.320.100	Trim right
1	091.100.320.101	Trim left
1	091.100.320.102	Adhesive label side mirror panel R
1	091.100.320.103	Adhesive label side mirror panel L
1	00091089010031	Bond and Seal black, 70 ml tube



ASSEMBLY INSTRUCTIONS

TECHART Trims

Quantity	Part number	Part designation
1	091.100.500.009	Diffusor add-on Carrera until MY16
Consisting of:		
1	091.100.500.100	Diffusor add-on
4	000.100.999.999	Collar screw for plastic PT 50x16 with cone point
1	00091089010031	Bond and Seal black, 70 ml tube

Quantity	Part number	Part designation
1	091.100.502.009	Diffusor add-on Carrera from MY17
Consisting of:		
1	091.100.502.100	Diffusor add-on
4	000.100.999.999	Collar screw for plastic PT 50x16 with cone point
1	00091089010031	Bond and Seal black, 70 ml tube

Quantity	Part number	Part designation
1	091.100.512.009	Diffusor add-on for rear apron with centered outlet Carrera from MY17
Consisting of:		
1	091.100.512.100	Diffusor
2	0039004.8X251025	Sheet metal screw fillister head with flange 4.8x25
2	0039004.8X191025	Sheet metal screw fillister head with flange 4.8x19
1	00091089010031	Bond and Seal black, 70 ml tube

Quantity	Part number	Part designation
1	091.100.552.009	Shaft panels with louvers for rear apron
Consisting of:		
1	091.100.552.100	Louver right
1	091.100.552.101	Louver left
1	091.100.552.110	Frame for louver right
1	091.100.552.111	Frame for louver left
4	0009002.9X9.5	Sheet metal screw fillister head, 2.9x9.5
1	00091089010031	Bond and Seal black, 70 ml tube



ASSEMBLY INSTRUCTIONS

TECHART Trims

Quantity	Part number	Part designation
1	091.100.580.009	Diffusor add-on Turbo until MY16
Consisting of:		
1	091.100.580.100	Diffusor add-on
2	000.100.999.999	Collar screw for plastic PT 50x16 with cone point
2	0039004.8X257981	Collar screw 4.8x25, black
1	00091089010031	Bond and Seal black, 70 ml tube

Quantity	Part number	Part designation
1	091.100.582.009	Diffusor add-on Turbo from MY17
Consisting of:		
1	091.100.582.100	Diffusor add-on
2	000.100.999.999	Collar screw for plastic PT 50x16 with cone point
2	0039004.8X257981	Collar screw 4.8x25, black
1	00091089010031	Bond and Seal black, 70 ml tube

Quantity	Part number	Part designation
1	091.100.600.009	Roof spoiler
Consisting of:		
1	091.100.600.100	Roof spoiler
1.1	000961894910-95	Adhesive tape for trims 6 mm x 0.95
1	00091089010031	Bond and Seal black, 70 ml tube

Please, use the table to check whether all of the required parts are present.

Once parts have been removed from their original packaging, ensure that they are properly handled and stored.



ASSEMBLY INSTRUCTIONS

TECHART Trims

III Installation

1 Prepare vehicle



Before starting work, check that the vehicle is free of defects. Use the PIWIS system tester to read out all of the fault memories of the individual vehicle components and first rectify any faults displayed.

1.1 Paint preparation

TECHART roof spoiler

- 1 Mask the TECHART roof spoiler on the inside, but do not paint.



Fig. 01



ASSEMBLY INSTRUCTIONS

TECHART Trims

2 TECHART aero wing trims Carrera 2 / 2S

 The bonding surfaces of the TECHART trim panels and the original front apron must be dry and free of dust.

Use cleaning agent to thoroughly degrease bonding surfaces on the TECHART trim panels and the original front apron. Then sand it down using 100-180 grade abrasive paper and finally use cleaning agent to degrease it again.

Do not touch the surfaces after they have been cleaned.

2.1 Dismantle original trim bars

1 Unclip both original trim bars.

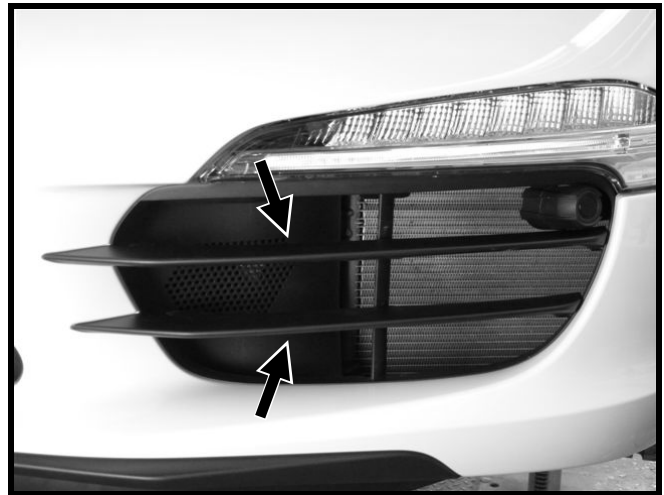

Fig. 02

2 Cut both trim bars to the center outside at the frame and at the center bar.

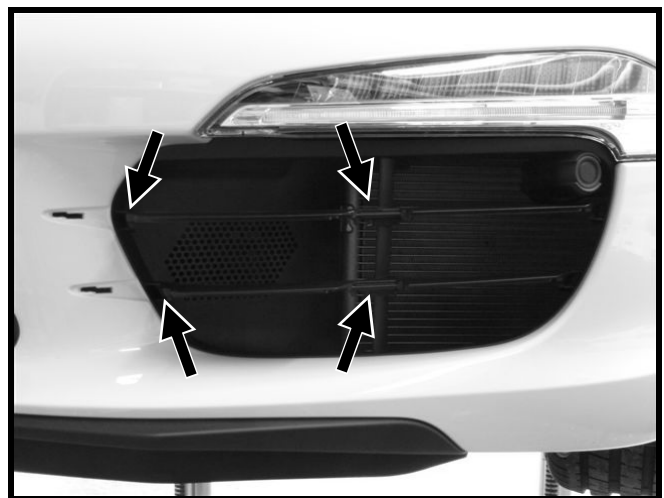

Fig. 03

 Caution, do not damage or scratch the frame!

2.2 Install TECHART aero wing trims

- 1 Apply a thin even coating of PU adhesive to the bonding surfaces.
- 2 Insert TECHART trim bar inside top 091.100.110.22_ (1) and TECHART trim bar inside bottom 091.100.110.23_ (2) into the front apron.

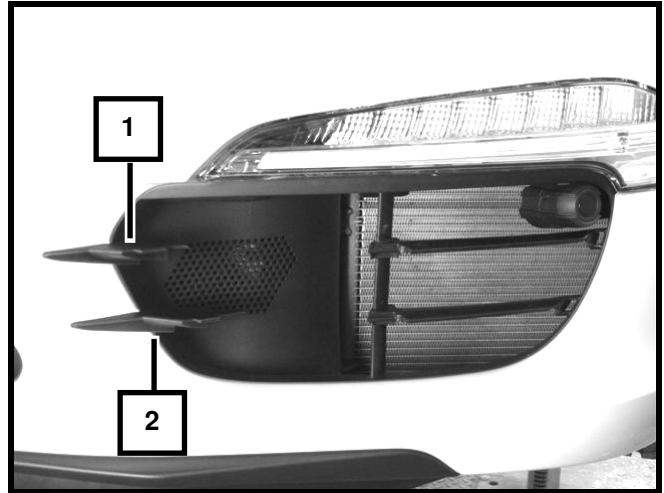

Fig. 04

- 3 Slide the TECHART carrier 091.100.110.11_ (3) into the front apron and slip it onto the TECHART trim bars inside and align.
- 4 Fasten the TECHART carrier (3) top and bottom with 2 screws 50x16 each to the front apron.

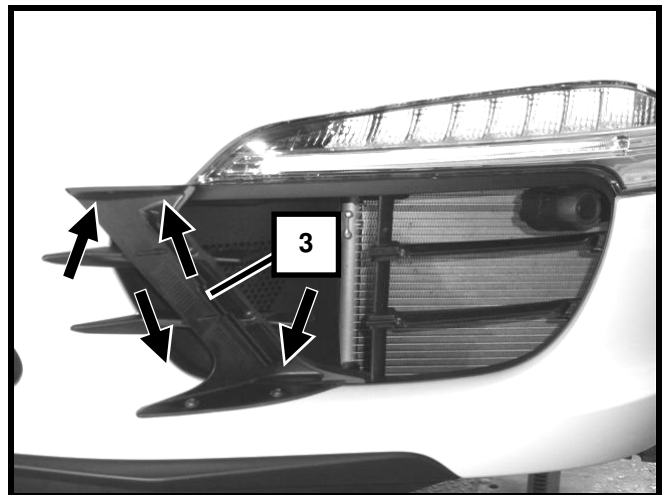

Fig. 05

- 5 Apply the PU-adhesive in front of the TECHART carrier (3) onto the front apron for an additional fixation of the TECHART panel endings 091.100.110.10_ (4).

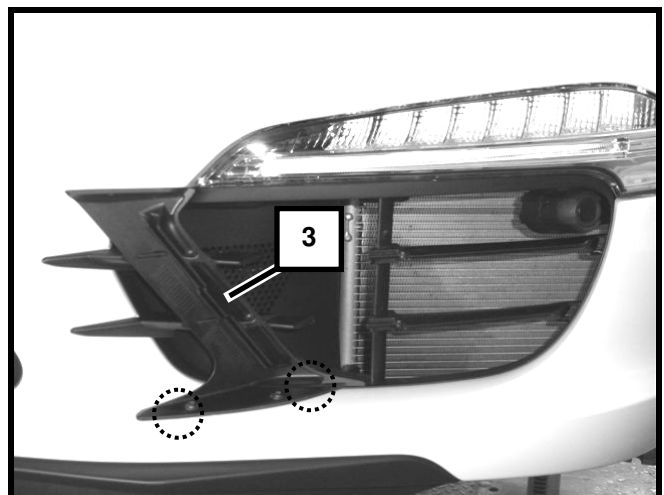

Fig. 06

- 6 Attach the TECHART clip 000.100.340.900 to the TECHART panel 091.100.110.10_ (4).
- 7 Clip the TECHART panel (4) to the TECHART carrier (3).

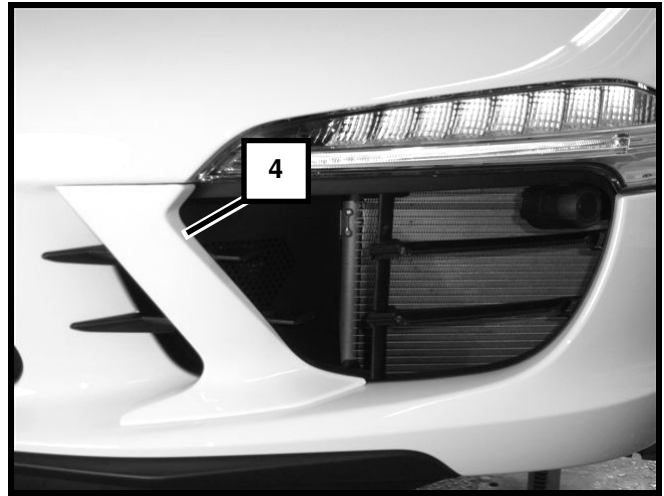

Fig. 07

- 8 Apply a thin even coating of PU adhesive to the bonding surfaces.
- 9 Glue the TECHART trim bar outside top 091.100.110.20_ (5) and the TECHART trim bar outside bottom 091.100.110.21_ (6) to the inside of the TECHART carrier (3) and clip it into the outside of the original frame.

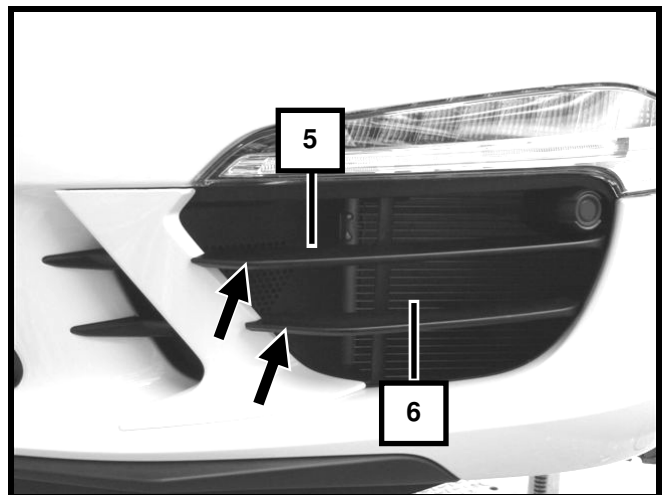



Fig. 08

-  **Press on the parts firmly in the bonding area. Ensure an accurate fit and remove any escaping adhesive with cleaning agent.**
-  **Allow to dry for at least 12 hours.**



ASSEMBLY INSTRUCTIONS

TECHART Trims

3 TECHART aero wing trims Carrera 4 / 4S

Only for vehicles with parking sensor



The bonding surfaces of the TECHART trim panels and the original front apron must be dry and free of dust.

Use cleaning agent to thoroughly degrease bonding surfaces on the TECHART trim panels and the original front apron. Then sand it down using 100-180 grade abrasive paper and finally use cleaning agent to degrease it again.

Do not touch the surfaces after they have been cleaned.

3.1 Dismantle original trim bars

- 1 Unclip both original trim bars, unplug parking assistant.
- 2 Unclip parking assistant from trim bar.

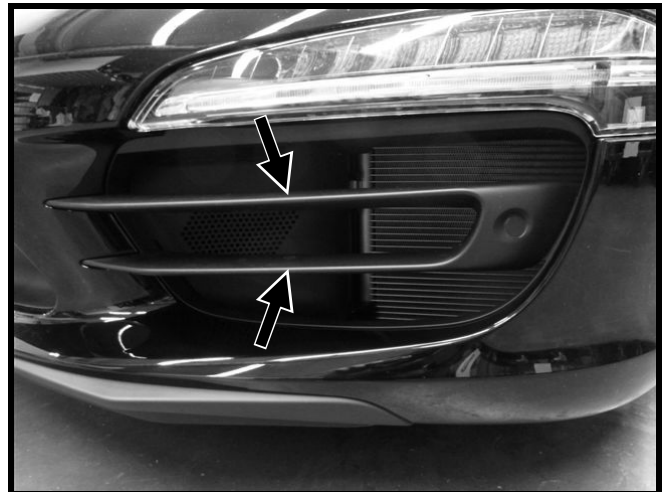

Fig. 09

3.2 Prepare original grille

- 1 Cut both trim bars at the frame towards the center and also at the bend on the outside.

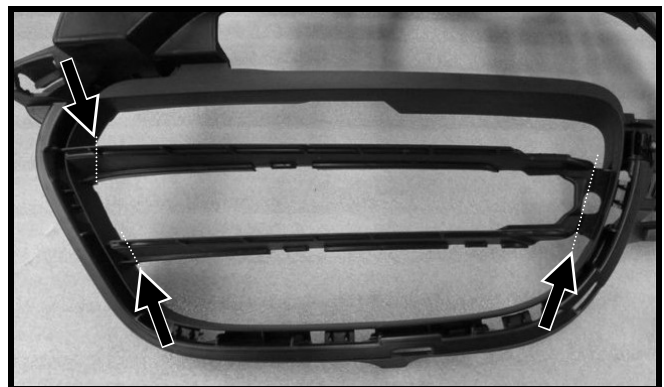

Fig. 10



Caution, do not damage or scratch the frame!

3.3 Install TECHART aero wing trims

- 1 Apply a thin even coating of PU adhesive to the bonding surfaces.
- 2 Insert TECHART trim bar inside top 091.100.110.22_ (1) and TECHART trim bar inside bottom 091.100.110.23_ (2) into the front apron.

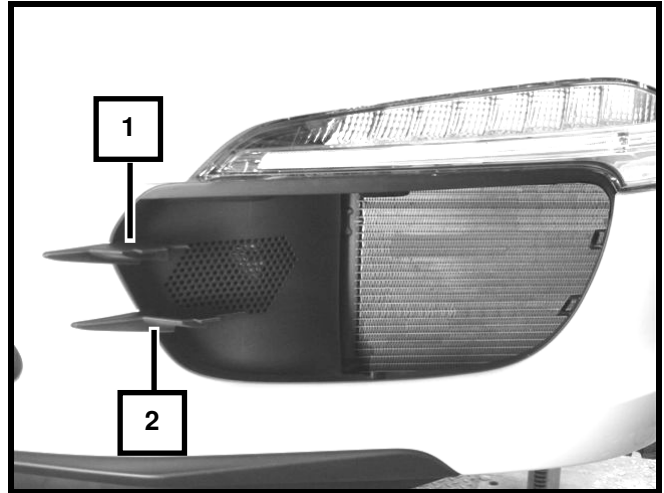

Fig. 11

- 3 Slide the TECHART carrier 091.100.110.11_ (3) into the front apron and slip it onto the TECHART trim bars inside and align.
- 4 Fasten the TECHART carrier (3) top and bottom each with 2 screws 50x16 to the front apron.

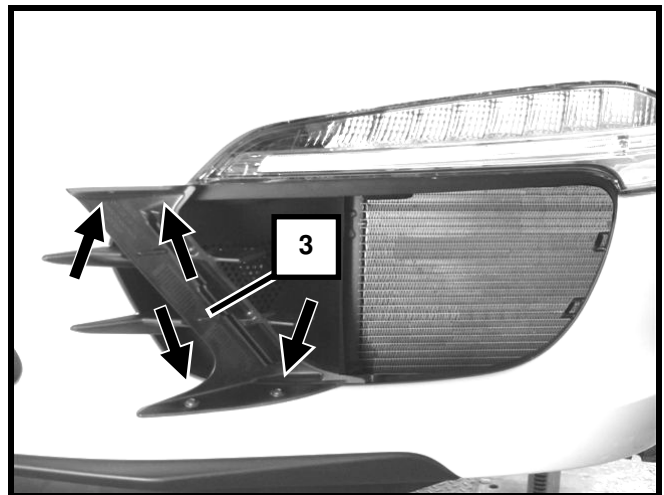

Fig. 12

- 5 Apply the PU-adhesive in front of the TECHART carrier (3) onto the front apron for an additional fixation of the TECHART panel endings 091.100.110.10_ (4).

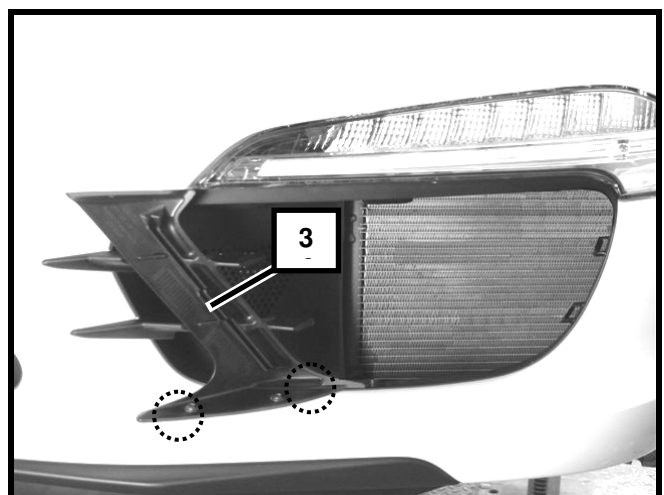

Fig. 13

- 6 Slide the TECHART clip 000.100.340.900 to the TECHART panel 091.100.110.10_ (4).
- 7 Clip the TECHART panel (4) to the TECHART carrier (3).

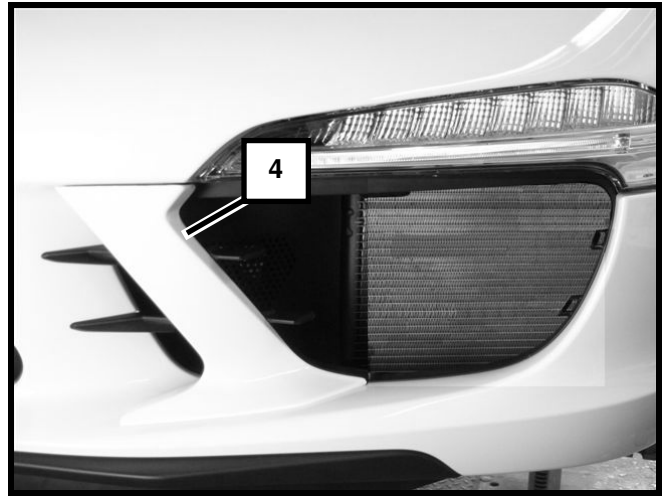

Fig. 14

- 8 Install the TECHART panel parking sensor 091.100.111.20_ (6a) and tighten with the screws 2.9x13 and the TECHART bracket 091.100.111.20_ (6b).
- 9 Apply a thin even coating of PU adhesive to the bonding surfaces. Glue the TECHART trim bar outside top 091.100.110.20_ (5) to the TECHART bracket parking sensor (6a). Flush on the rear and the inside.

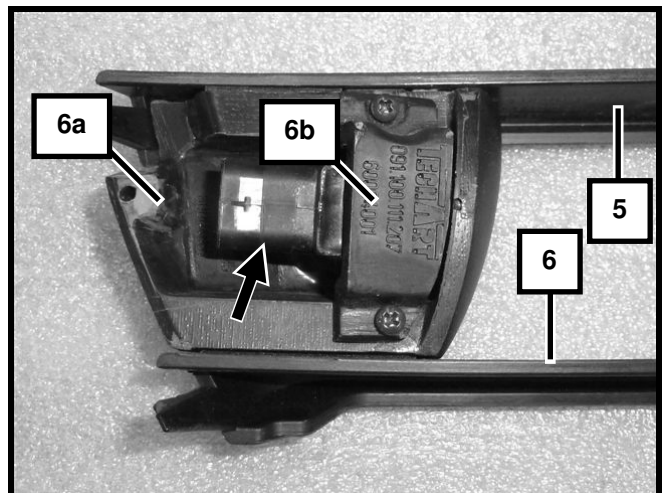

Fig. 15

- 10 Apply a thin even coating of PU adhesive to the bonding surfaces. Glue the TECHART bracket parking sensor (6a) to the TECHART trim bar outside bottom 091.100.110.21_ (6).
- 11 Apply a thin even thin coating of PU adhesive to the bonding surfaces. Glue the TECHART trim bar outside top (5) and the TECHART trim bar outside bottom (6) to the inside of the TECHART carrier (3) and glue on the outside the TECHART bracket parking sensor (6a) to the grille.

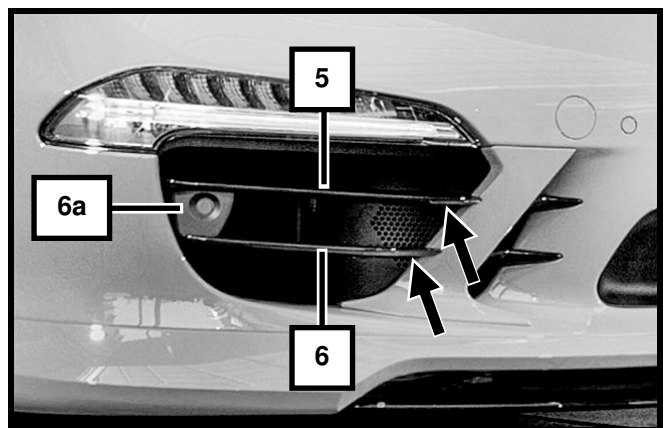

Fig. 16



ASSEMBLY INSTRUCTIONS

TECHART Trims

- 12 Fasten the TECHART panel parking sensor (6a) with the screw 2.9x16 to the grille.

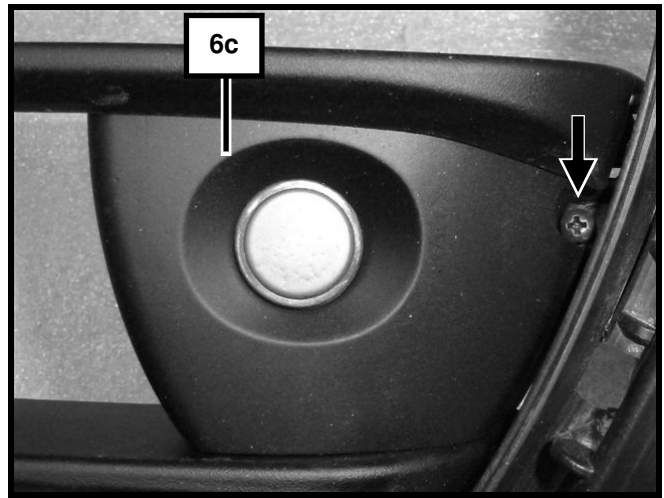

Fig. 17

 Press on the parts firmly in the bonding area. Ensure an accurate fit and remove any escaping adhesive with cleaning agent.

 Allow to dry for at least 12 hours.



ASSEMBLY INSTRUCTIONS

TECHART Trims

4 TECHART aero wing trims Carrera 4 / 4S

Only for vehicles without parking sensor



The bonding surfaces of the TECHART trim panels and the original front apron must be dry and free of dust.

Use cleaning agent to thoroughly degrease bonding surfaces on the TECHART trim panels and the original front apron. Then sand it down using 100-180 grade abrasive paper and finally use cleaning agent to degrease it again.

Do not touch the surfaces after they have been cleaned.

4.1 Dismantle original trim bars

- 1 Unclip both original trim bars.

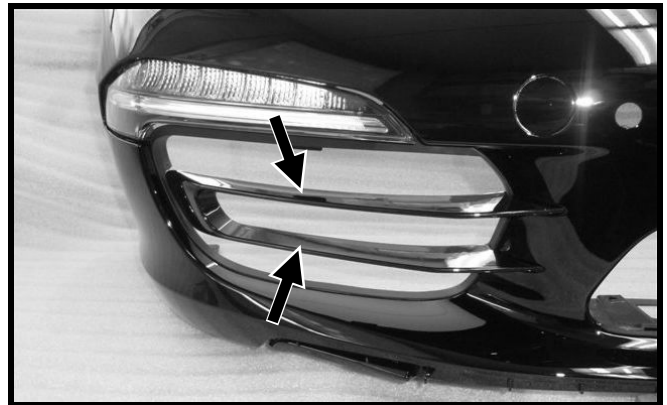

Fig. 18

4.2 Prepare original grille

- 1 Cut both trim bars flush towards the center and outside.

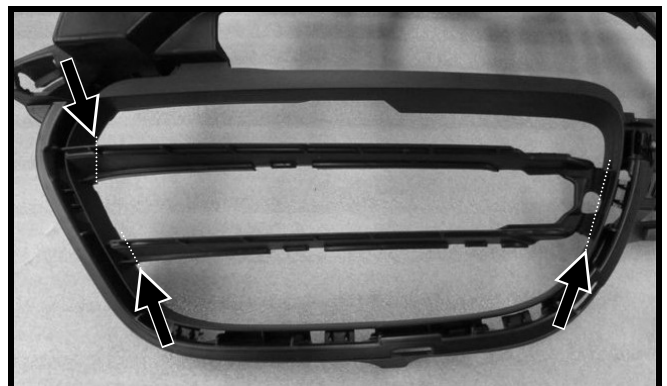

Fig. 19



Caution, do not damage or scratch the frame!



ASSEMBLY INSTRUCTIONS

TECHART Trims

- 2 Attach the TECHART bracket w/o parking sensor 091.100.111.20_ (6c) and slide upwards all the way to the stop.
- 3 Fasten the TECHART bracket w/o parking sensor (6c) with the screw 2.9x16 to the grille.

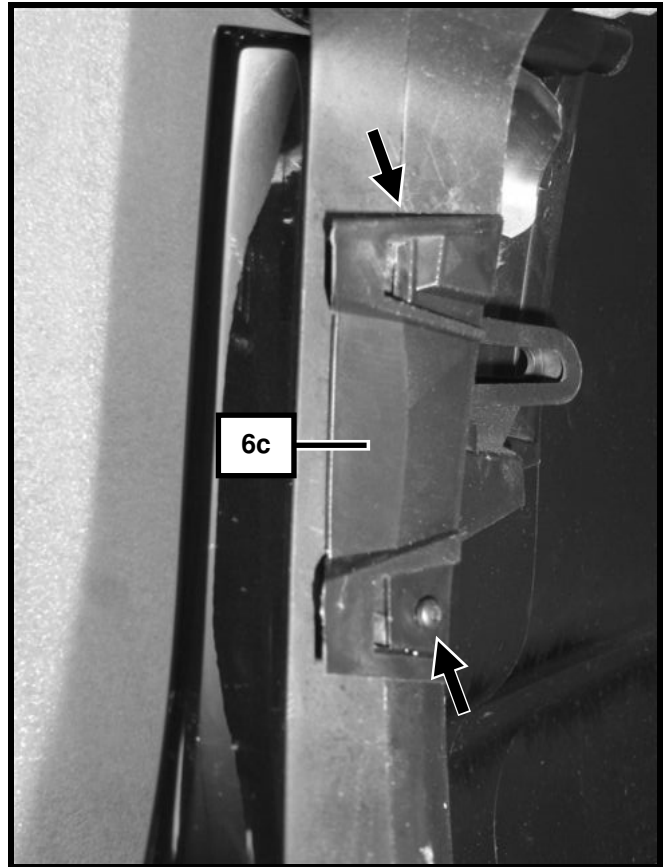

Fig. 20

4.3 Install TECHART aero wing trims

- 1 Apply a thin even coating of PU adhesive to the bonding surfaces.
- 2 Insert TECHART trim bar inside top 091.100.110.22_ (1) and TECHART trim bar inside bottom 091.100.110.23_ (2) into the front apron.

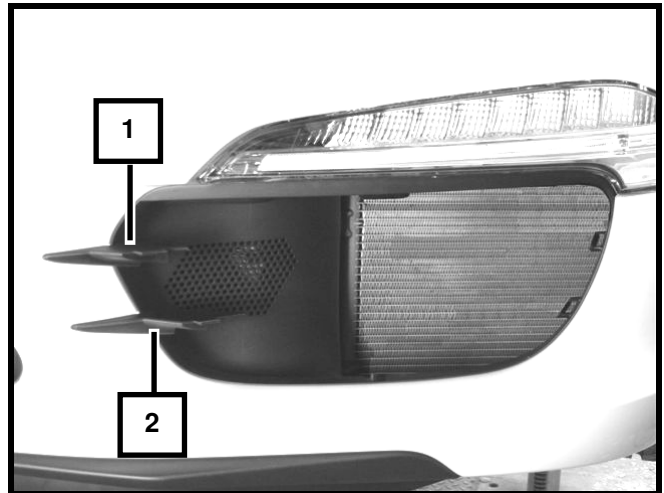

Fig. 21

- 3 Slide the TECHART carrier 091.100.110.11_ (3) into the front apron and slip it onto the TECHART trim bars inside and align.
- 4 Fasten the TECHART carrier (3) top and bottom with 2 screws 50x16 each to the front apron.

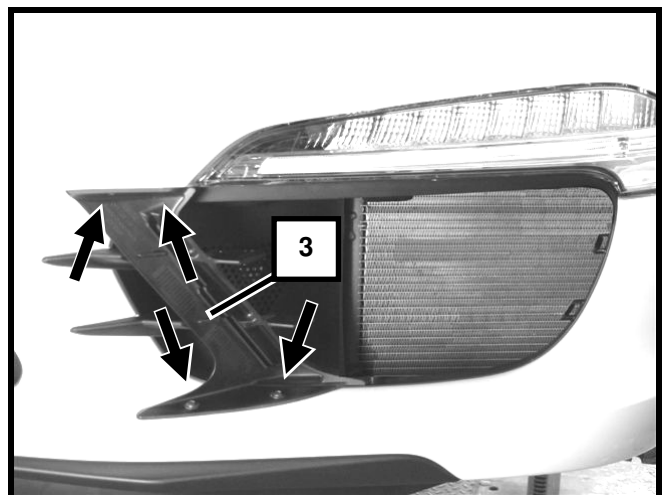

Fig. 22

- 5 Apply the PU-adhesive in front of the TECHART carrier (3) onto the front apron for an additional fixation of the TECHART panel endings 091.100.110.10_ (4).

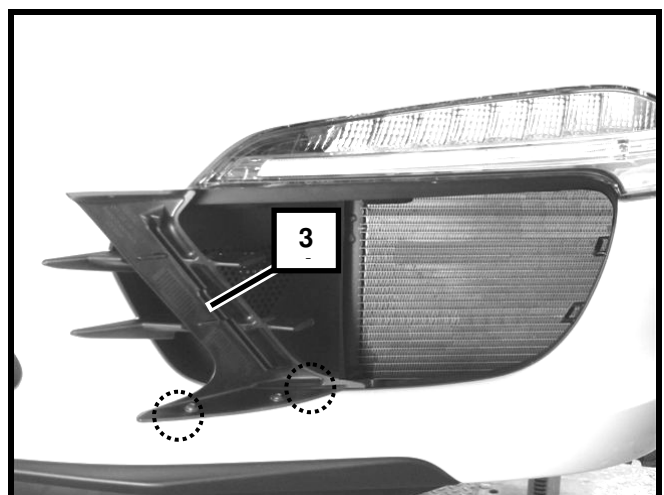

Fig. 23



ASSEMBLY INSTRUCTIONS

TECHART Trims

- 6 Slide the TECHART clip 000.100.340.900. to the TECHART panel 091.100.110.10_ (4).
- 7 Clip the TECHART panel (4) to the TECHART carrier (3).

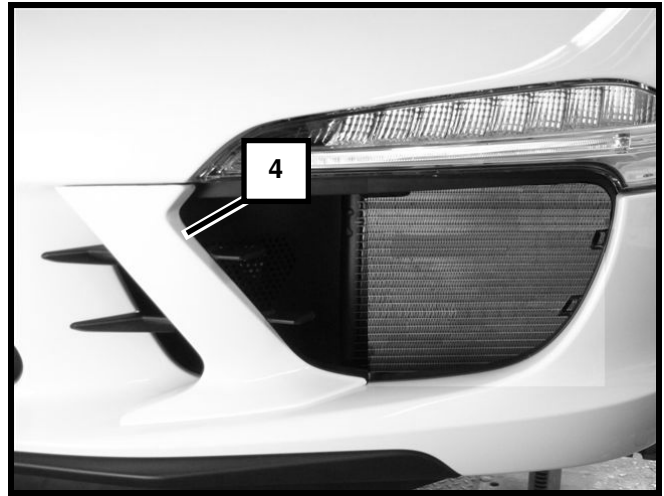

Fig. 24

- 8 Apply a thin even coating of PU adhesive to the bonding surfaces.
- 9 Glue the TECHART trim bar outside top 091.100.110.20_ (5) and the TECHART trim bar outside bottom 091.100.110.21_ (6) to the inside of the TECHART carrier (3) and clip it into the outside of the TECHART bracket without parking sensor (6c).

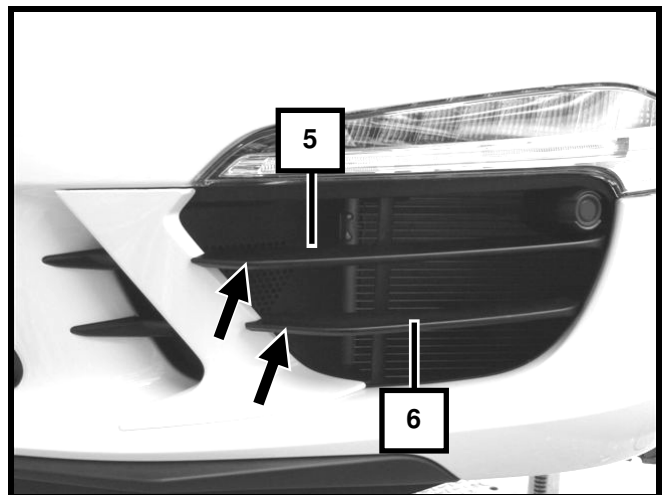



Fig. 25

-  **Press on the parts firmly in the bonding area. Ensure an accurate fit and remove any escaping adhesive with cleaning agent.**
-  **Allow to dry for at least 12 hours.**



ASSEMBLY INSTRUCTIONS

TECHART Trims

5 TECHART aero wing trims Turbo

-  The bonding surfaces of the TECHART trim panels and the original front apron must be dry and free of dust.

Use cleaning agent to thoroughly degrease bonding surfaces on the TECHART trim panels and the original front apron. Then sand it down using 100-180 grade abrasive paper and finally use cleaning agent to degrease it again.

Do not touch the surfaces after they have been cleaned.

5.1 Install TECHART aero wing trims

- 1 Apply a thin even coating of PU adhesive to the bonding surfaces of the TECHART aero wings 091.100.183.10_ (17).
- 2 Fit the TECHART aero wings on to the grille.

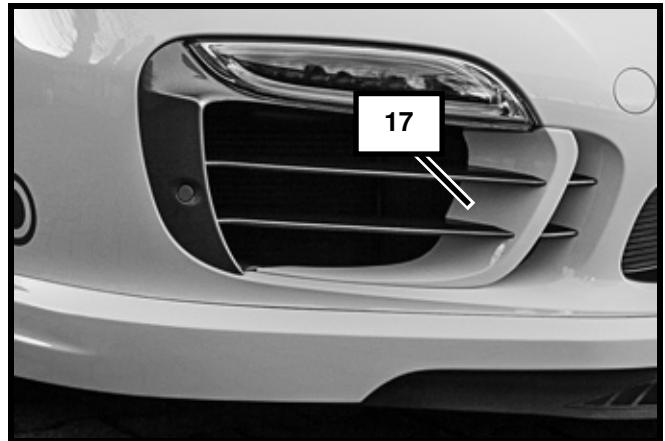

Fig. 34a

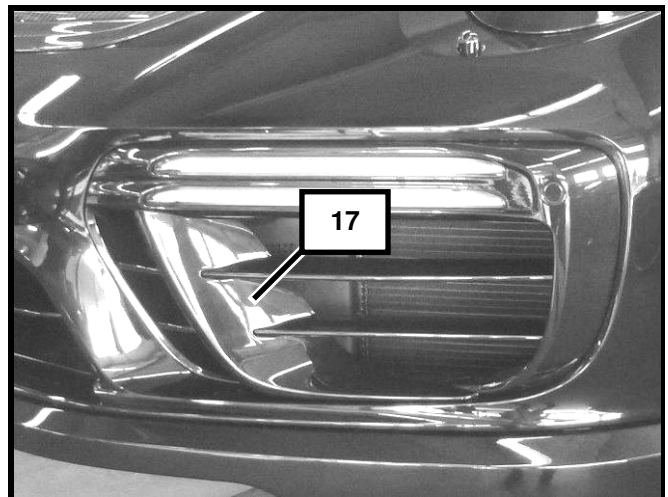

Fig. 34b

-  Press on the parts firmly in the bonding area. Ensure an accurate fit and remove any escaping adhesive with cleaning agent.

-  Allow to dry for at least 12 hours.



ASSEMBLY INSTRUCTIONS

TECHART Trims

6 TECHART air outlet grille



The bonding surfaces of the TECHART outlet grille, the bottom part and the original front apron must be dry and free of dust.

Use cleaning agent to thoroughly degrease bonding surfaces on the TECHART outlet grille, the bottom part and the original front apron. Then sand it down using 100-180 grade abrasive paper and finally use cleaning agent to degrease it again.

Do not touch the surfaces after they have been cleaned.

6.1 Dismount wheels and add-on parts

- 1 Raise vehicle at the factory-fitted jacking points.
- 2 Detach front wheels.

6.2 Install TECHART air outlet grille

- 1 Open front flap.
- 2 Remove main headlights.
- 3 Detach PU-cover of the battery.
- 4 Unclip PU-cover on the side.
- 5 Remove PU-cover around the hood lock.

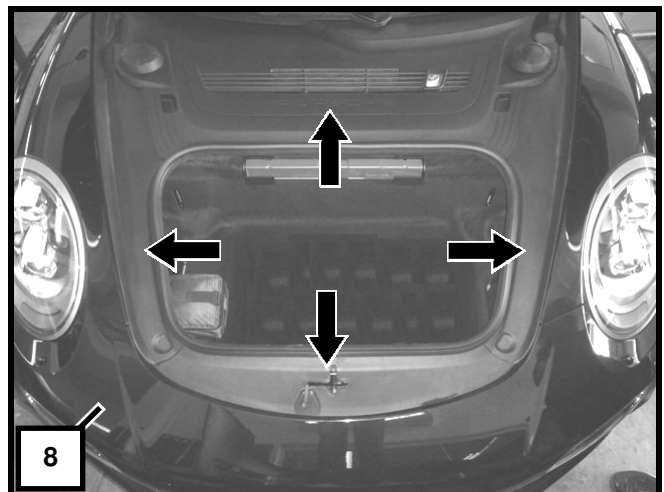

Fig. 26

- 6 Unscrew the center fixation screw of the front apron (8).
- 7 Mark the center of the front apron (8) with an adhesive tape.

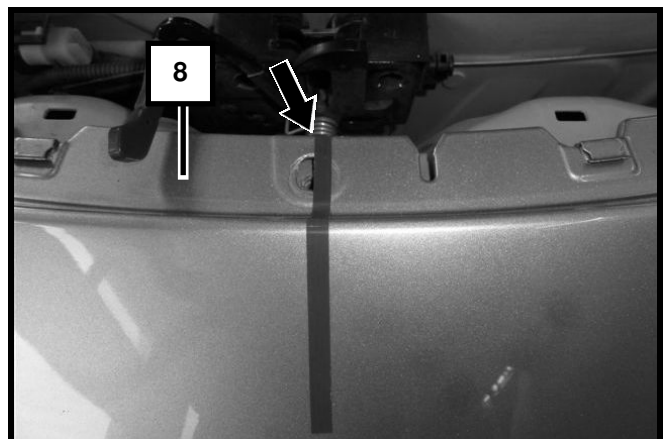

Fig. 27

- 8 Cut the TECHART cutting template 091.140.182.009 (7).
- 9 Align the TECHART cutting template (7) at the center marking, check if the distance to the left and right fender is identical and then stick it to the front apron (8).

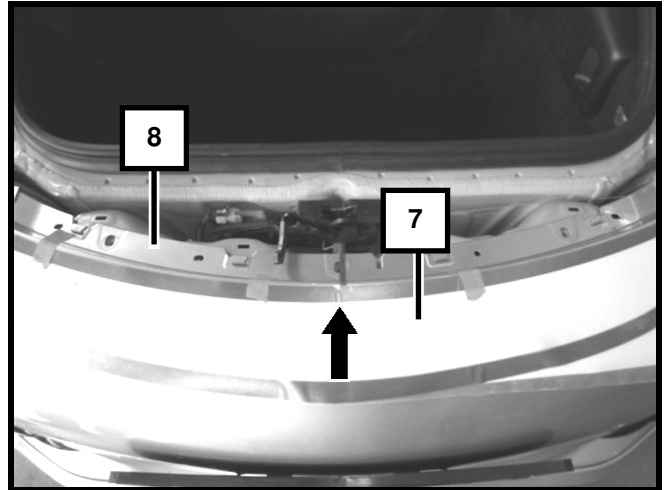

Fig. 28

- 10 Unscrew the top fixing screws (10) from the front apron (8).
- 11 Detach retaining bracket between headlamp and front flap towards the flap (see arrow).
- 12 Unscrew all bolts of the inner wheel arch lining.
- 13 Remove inner wheel arch lining including brake air duct.

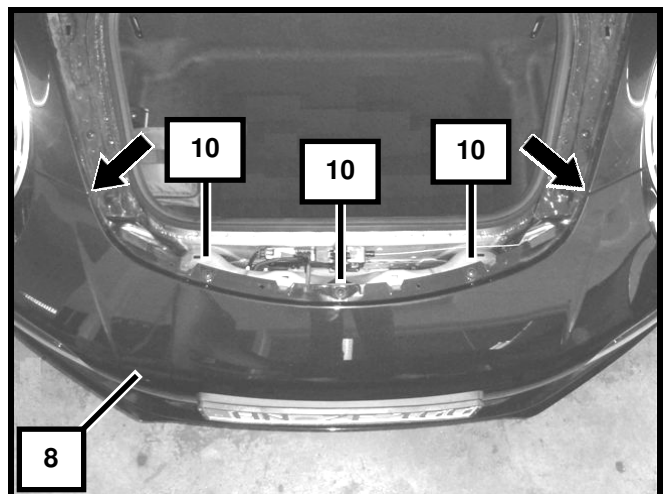

Fig. 29

- 14 Unscrew mounting bolts (11) on underside of vehicle and from brake air duct.

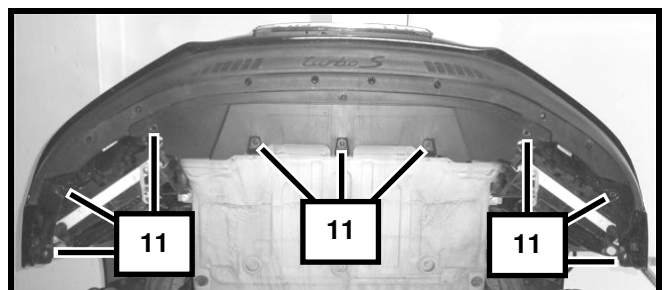

Fig. 30

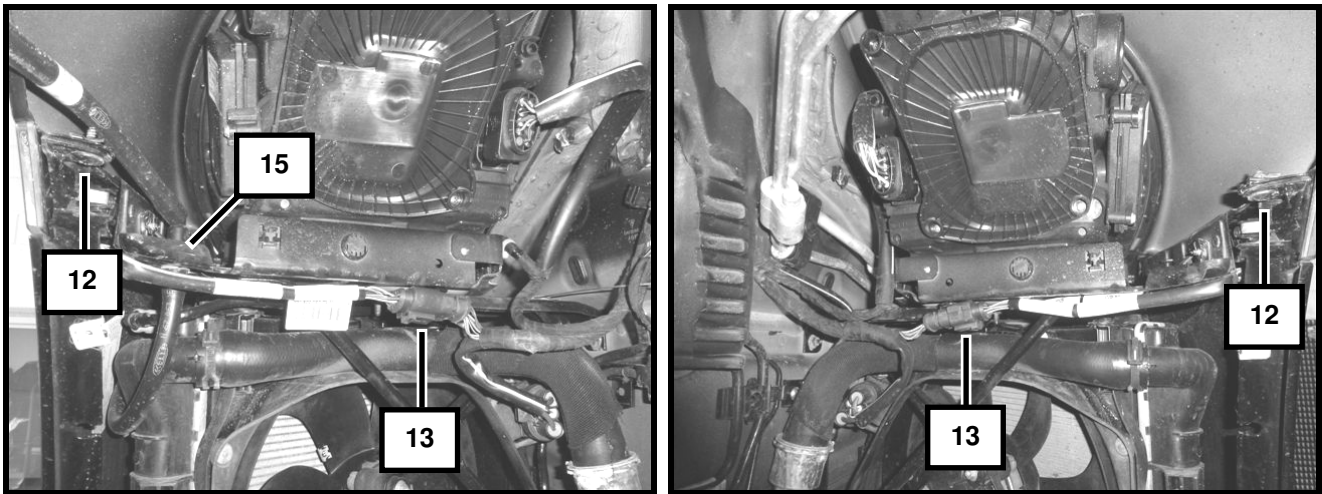

Fig. 31

15 Remove side-mounted turn signal.

16 Unscrew mounting bolts (1 each side) (12) from side of wheel arch.

17 Disconnect electrical connection (13) on right and left of wheel arch at headlamp bracket.

18 Disconnect water hose (14) on left of wheel arch.



Water may run out when the water hose is disconnected. Collect the water in a suitable receptacle.

19 Detach the original front apron towards the front. Remove vacuum hoses (Turbo only).

20 Dismantle the water hose, sensors and antenna at the front area.

21 Modify front apron, remove the carrier foil of the TECHART cutting template (7) and cut out the marked hole.



Care for an accurate fit.

Vehicles starting MY17:

22 Dismantle PU-carrier from the front apron.

23 Modify PU-carrier.

24 Install the PU-carrier into the front apron and clinch.

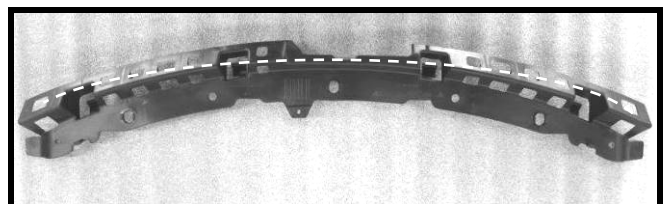

Fig. 32

- 25 Apply PU-adhesive to the bonding area of the TECHART bottom part 091.100.182.101 (15).
- 26 Set the TECHART bottom part (15) flush with the hole into the front apron (8).

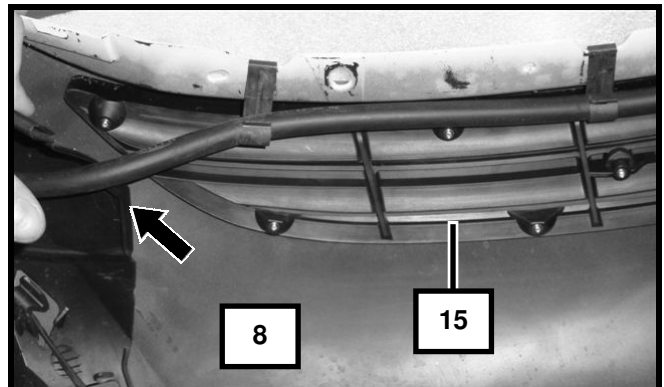

Fig. 33

- 27 Mount the TECHART air outlet grille 091.100.182.100 (9) into the hole of the front apron (8).
- 28 Attach the TECHART bottom part (15) and tighten with the screws 2.9x13 into the TECHART air outlet grille (9). If necessary unhinge the grille and press to the side, see arrow on fig. 32.
- 29 Reinstall the water hose; stick the sensor from the rear bottom flush to the TECHART bottom part (15).

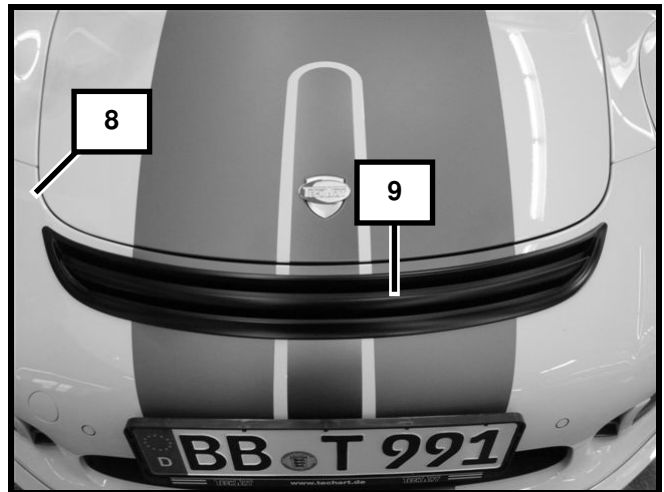

Fig. 34

 **Care for an accurate fit.**

- 30 Work on plastic cover (16):
 - leave left and right A1 = 50mm.
 - cut A2 = 20mm.
 - Paint black on the top

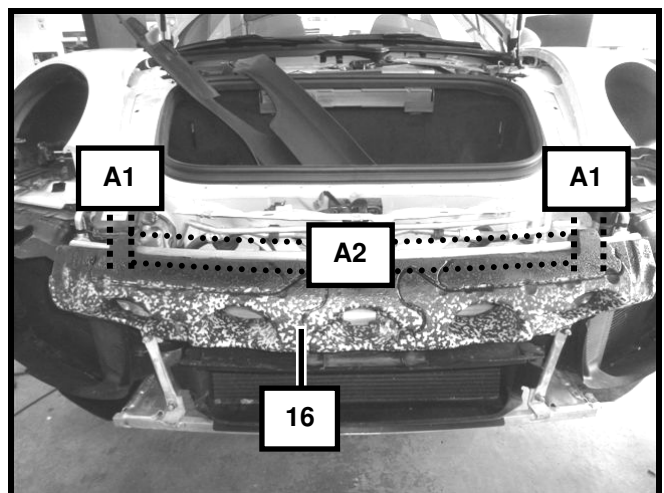

Fig. 35



ASSEMBLY INSTRUCTIONS

TECHART Trims

- 31 Slide the front apron at the vehicle into the original guides and tighten to the original fixing point.
- 32 Connect the electrical connections inside the wheel arch right and the water hose for the headlight washer.
- 33 Install wheel house shells.
- 34 Install headlights.
- 35 Mount front wheels.



ASSEMBLY INSTRUCTIONS

TECHART Trims

7 TECHART headlight trims

i The bonding surfaces of the TECHART trim panels and the headlight washer panels must be dry and free of dust.

Use cleaning agent to thoroughly degrease bonding surfaces on the TECHART trim panels and the headlight washer panels. Then sand it down using 100-180 grade abrasive paper and finally use cleaning agent to degrease it again.

Do not touch the surfaces after they have been cleaned.

7.1 Dismantle headlight washer panels

- 1 Pull out the spraying nozzles and unclip the panel.

7.2 Install TECHART headlight trims

- 1 Apply a thin even coating of PU adhesive to the TECHART trims 091.100.200.10_ (18).
- 2 Fit the TECHART trims.
- 3 Apply a thin even coating of PU adhesive to the nozzles.
- 4 Fit the TECHART headlight washer panels 097.100.220.100-01 (19).

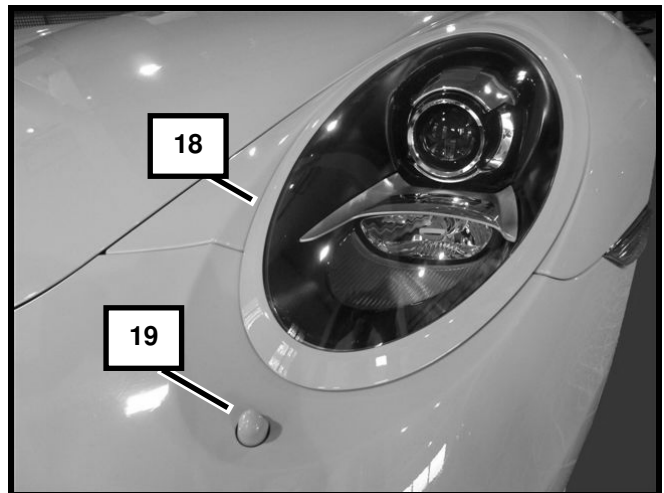

Fig. 36

i Press on the parts firmly in the bonding area. Ensure an accurate fit and remove any escaping adhesive with cleaning agent.

- 5 Fix the TECHART trim panels and the TECHART headlight washer panel in place with adhesive tape so that they have firm contact with the surface at all points.

i Allow to dry for at least 12 hours.



ASSEMBLY INSTRUCTIONS

TECHART Trims

8 TECHART side mirror trims

-  The bonding surfaces of the TECHART trim panels and the original side mirrors must be dry and free of dust.

Use cleaning agent to thoroughly degrease bonding surfaces on the TECHART trim panels and the original side mirrors. Then sand it down using 100-180 grade abrasive paper and finally use cleaning agent to degrease it again.

Do not touch the surfaces after they have been cleaned.

8.1 Install TECHART side mirror trims

- 1 Apply a thin even coating of PU adhesive to the TECHART trims 091.100.320.10_ (20).
- 2 Set the TECHART trims 2mm below the edge.

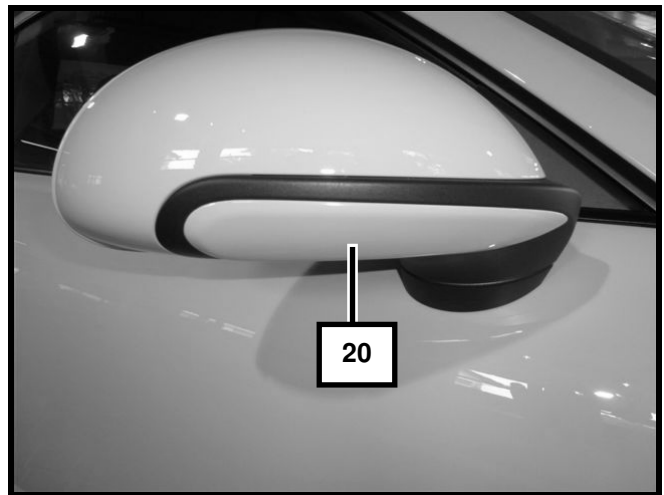

Fig. 37

-  Press on the parts firmly in the bonding area. Ensure an accurate fit and remove any escaping adhesive with cleaning agent.

- 3 Fix the TECHART trims in place with adhesive tape so that they have firm contact with the surface at all points.

-  Allow to dry for at least 12 hours.



ASSEMBLY INSTRUCTIONS

TECHART Trims

9 TECHART diffuser add-on

-  The gluing surfaces on the TECHART diffuser add-on and the original diffuser must be dry and free of dust or paint spraying mist!

Thoroughly degrease the gluing surfaces on the TECHART diffuser add-on and the original diffuser using a cleaning agent. Then sand it down using 100-180 grade abrasive paper and finally use cleaning agent to degrease it again.

Do not touch the surfaces after they have been cleaned.

Apply plastic primer to the gluing surface of the original diffuser.

9.1 Install TECHART diffuser add-on

- 1 Apply a thin even coating of PU adhesive to the TECHART diffuser (21).

091.100.500.100 Carrera until MY16
091.100.502.100 Carrera from MY17
091.100.580.100 Turbo until MY16
091.100.582.100 Turbo from MY17

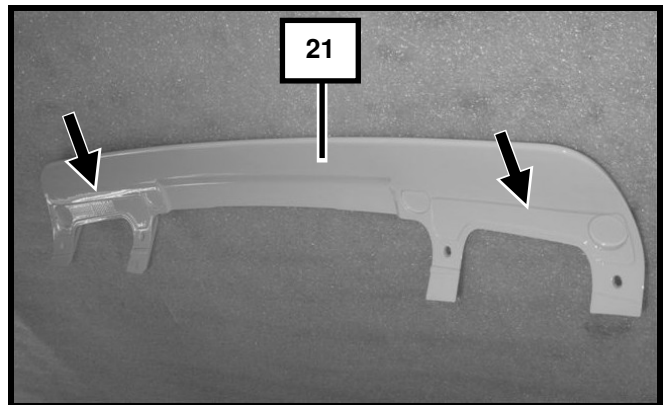



Fig. 38

-  Press on the parts firmly in the bonding area. Ensure an accurate fit and remove any escaping adhesive with cleaning agent.

- 2 Fasten the TECHART diffuser add-on (21) to the original diffuser from the bottom side with the screws 50x16.

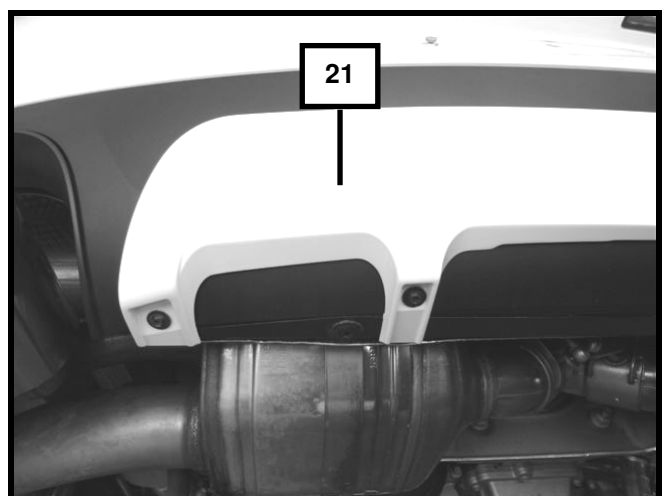

Fig. 39

-  Allow to dry for at least 12 hours.



ASSEMBLY INSTRUCTIONS

TECHART Trims

10 TECHART diffuser add-on for rear apron with centered outlet for Carrera from MY17

-  The gluing surfaces on the TECHART diffuser add-on and the original diffuser must be dry and free of dust or paint spraying mist!

Thoroughly degrease the gluing surfaces on the TECHART diffuser add-on and the original diffuser using a cleaning agent.

Do not touch the surfaces after they have been cleaned.

Apply plastic primer to the gluing surface of the original diffuser.

10.1 Install TECHART diffuser add-on Carrera

- 1 Apply a thin even coating of PU adhesive to the TECHART diffuser add-on 091.100.512.100 (22).

-  Press on the parts firmly in the bonding area. Ensure an accurate fit and remove any escaping adhesive with cleaning agent.

- 2 Tighten the TECHART diffuser (22) on the outer bottom side with the screws 4.8x25 and on the inner side with the screws 4.8x19 to the original diffuser.

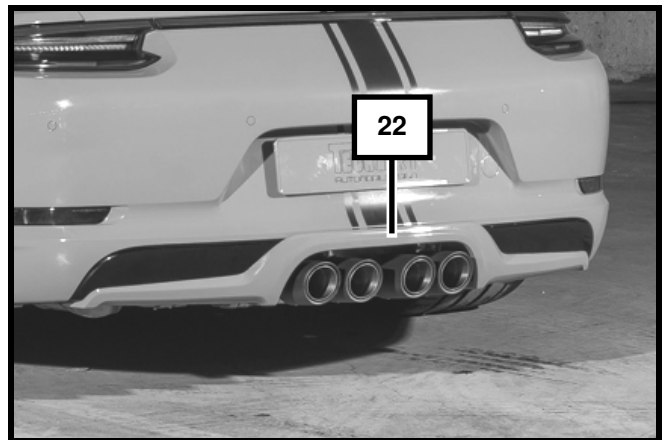

Fig. 40

-  Allow to dry for at least 12 hours.

11 TECHART louvers for rear apron

11.1 Install shaft panels with louvers for rear apron

-  The gluing surfaces on the TECHART frame and the original rear apron must be dry and free of dust or paint spraying mist!

Thoroughly degrease the gluing surfaces on the TECHART frame and the original rear apron using a cleaning agent. Then sand it down using 100-180 grade abrasive paper and finally use cleaning agent to degrease it again.

Do not touch the surfaces after they have been cleaned.

- 1 Insert the TECHART louver 091.100.552.10_ (23) into the TECHART frame 091.100.552.11_ (24) and tighten with the screws 2.9x9.5.

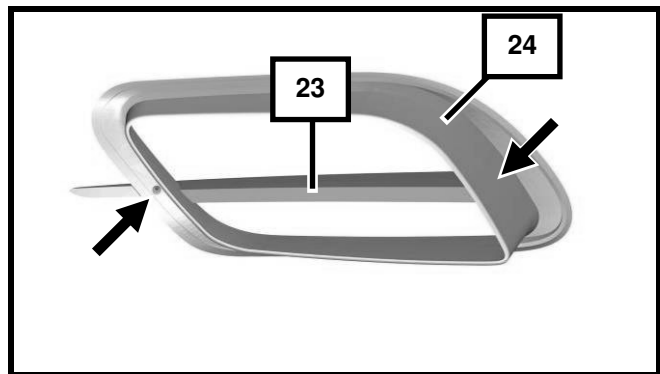

Fig. 41

- 2 Apply PU-adhesive to the bonding surface of the TECHART frame (24).
- 3 Install the TECHART frame (24) with the TECHART louver (23) into the air shaft of the rear apron.

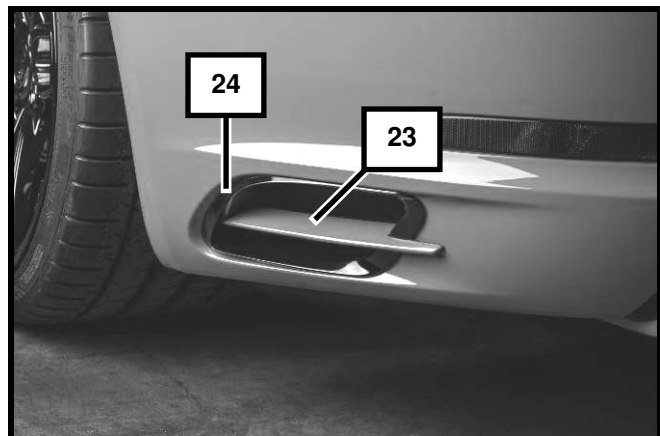

Fig 42

-  Press on the parts firmly in the bonding area. Ensure an accurate fit and remove any escaping adhesive with cleaning agent.

-  Allow to dry for at least 12 hours.

12 TECHART roof spoiler

-  The gluing surfaces on the TECHART roof spoiler and the original rear window must be dry and free of dust or paint spraying mist!**

Thoroughly degrease the gluing surfaces on the TECHART roof spoiler and the original rear window using a cleaning agent. Then sand it down using 100-180 grade abrasive paper and finally use cleaning agent to degrease it again.

Do not touch the surfaces after they have been cleaned.

12.1 Install TECHART roof spoiler

- 1 Stick double-sided tape 6mm x 0,95mm into the notch area (a) in the TECHART roof spoiler 091.100.600.100 (23).
- 2 Apply an even coating of PU adhesive to the gluing surface (b) of the TECHART roof spoiler (23).
- 3 Set TECHART trims 2mm below the edge.

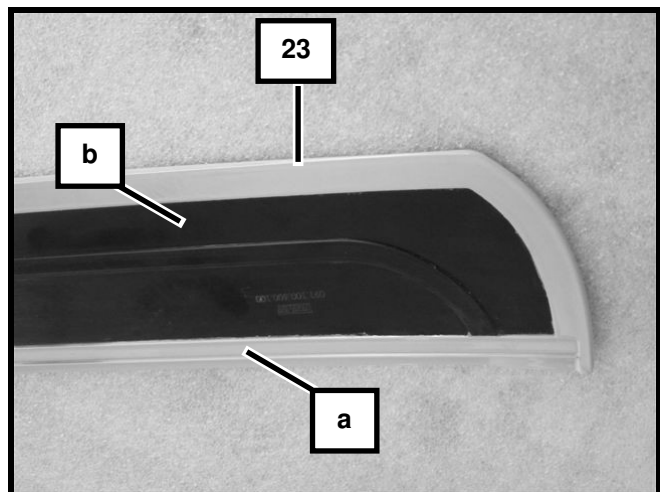



Fig. 43

-  Press on the parts firmly in the bonding area. Ensure an accurate fit and remove any escaping adhesive with cleaning agent.**

- 4 Fix the TECHART roof spoiler in place with adhesive tape so that it has firm contact with the surface at all points.

-  Allow to dry for at least 12 hours.**

-  For vehicles with rear window wiper: The original wiper blade has to be shortened by 100mm on the top.**

- remove end cap
- shorten the rubber for 100mm
- paste end cap



ASSEMBLY INSTRUCTIONS

TECHART Trims

13 Final inspection

- 1 Check the headlight setting and adjust the headlights if necessary.
- 2 Perform a general function check on the vehicle.



ASSEMBLY INSTRUCTIONS

TECHART Trims



TECHART AUTOMOBILDESIGN GMBH

RÖNTGENSTRASSE 47
71229 LEONBERG / GERMANY

TEL +49 7152 / 9339- 0

FAX +49 7152 / 9339-33

info@techart.de

www.techart.de

Subject to change at any time without prior notice.
Copyright 2018 by **TECHART** Automobildesign GmbH

Part No. 091.100.200.099